

FCCCHR - Request for Evaluation

(Revised 21 July 2004 - Page 2 of 3)

Submittal for Multiple Standards

A "Request for Evaluation" form is required with each individual submittal for evaluation. A submittal may include a request to evaluate a backflow prevention assembly to multiple standards. For example, an assembly submitted may be evaluated not only under the Foundation's standard in the **Manual of Cross-Connection Control - 9th edition**, but also to the latest version of standards from other agencies (i.e., American Water Works Association - AWWA, American Society of Sanitary Engineering - ASSE, Canadian Standards Association - CSA, International Association for Plumbing and Mechanical Officials - IAPMO, Underwriters Laboratory - UL or Factory Mutual - FM.)

Previous editions of some standards did not specify a particular order of the laboratory tests to be evaluated on the assembly, and as such, the laboratory test results of one standard might simultaneously be applicable for another standard(s). However, since many of the standards are now currently specifying the order of the laboratory tests, the assembly must be separately evaluated to each individual standard. Because of this, if only a single assembly for the 2 1/2"Ø and larger assemblies is submitted for evaluation to multiple standards, the assembly that is being evaluated may be subjected to an excessive amount of laboratory tests. Subjecting the assembly to an excessive amount of tests may result in unacceptable test results (i.e., failures). These unacceptable test results may be due to the excessive amount of tests, and not the design of the assembly.

Please select one of the following Options on the **Request for Evaluation Form**:

- Option #1. One (1) assembly for each make, model, and size may be submitted and evaluated to the multiple standards, or
- Option #2. Multiple assemblies for each make, model and size may be submitted so that an individual assembly is evaluated to a particular standard.

Contact the Foundation Staff for any additional information.

FCCCHR - Request for Evaluation

(Revised 21 July 2004 - Page 3 of 3)

Backflow Prevention Assembly Orientations

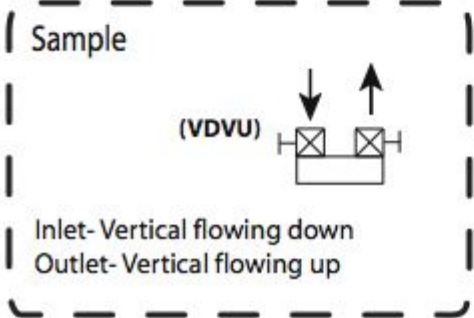
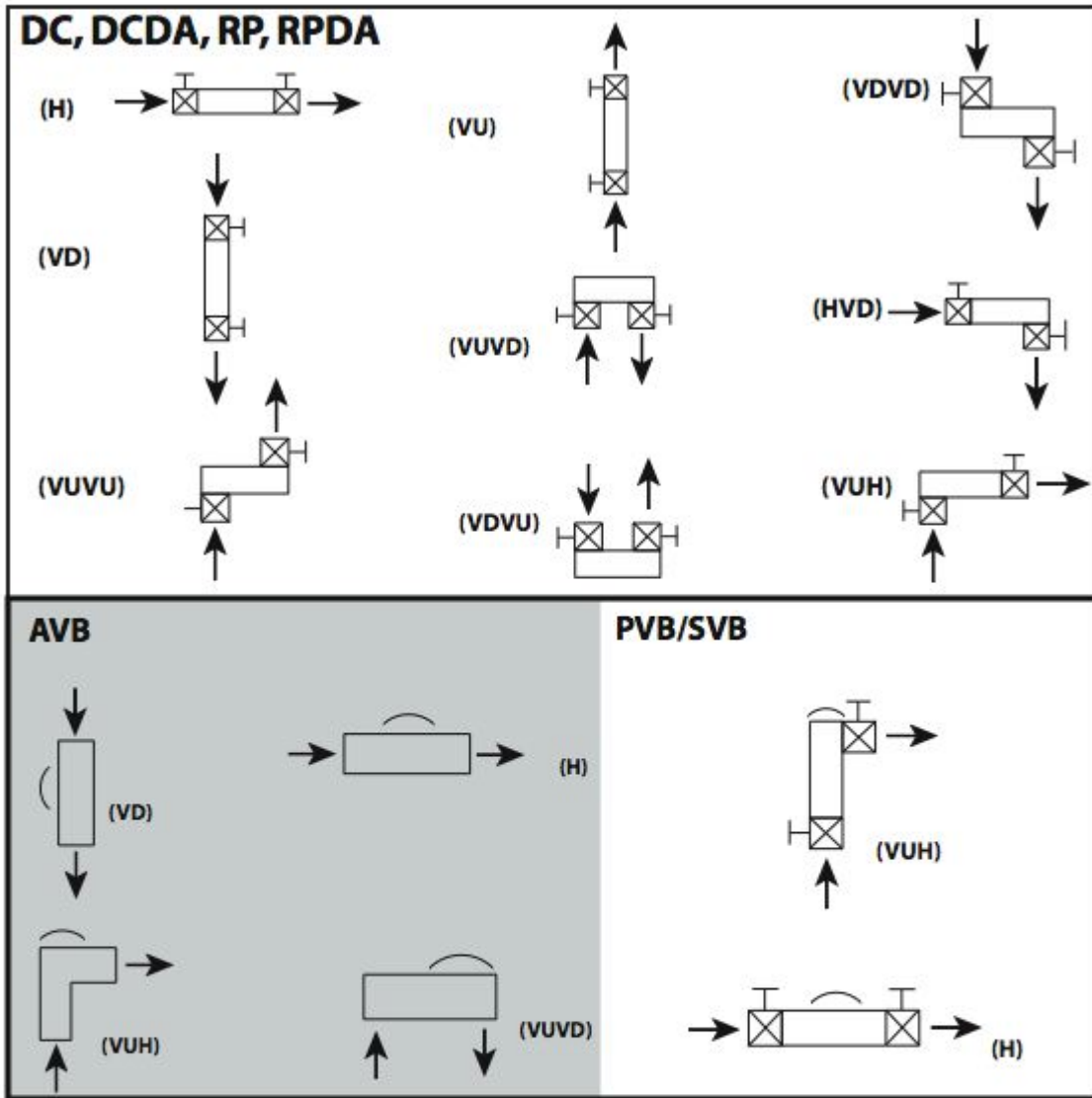

Key

(H) Horizontal (D) Down
(V) Vertical (U) Up

Shutoff Valve

Air inlet Valve

Direction of Flow