

## **THE ANSWER IS BLOWING IN THE WIND**

**CONCEPT** Students will learn that rotors, blades and wind speed are factors that determine how much electricity can be generated by a windmill.

**GOAL** Students will make three modern wind machines and determine which factors affect how well they turn with the least amount of wind.

**MATERIALS** Refer to "How Much Wind is Needed to Turn a Modern Wind Machine?" and "How Can you Measure Wind Energy?"

**HELPFUL HINTS USING TLM** Invite: Ask students what windmills in Holland are used for? (Surprisingly, not for energy! They are used to grind grain.) Refer to the previous activity to remind students that electricity is generated from something turning the shaft of a turbine. (Students that built a windmill in the last activity can use it as one of their "modern" wind machines.) Discover. Create. Ask Questions: refer to "How Much Wind is Needed to Turn a Modern Wind Machine?"

### **ACTIVITY**

See below: "How Much Wind is Needed to Turn a Modern Wind Machine?"

# HOW MUCH WIND IS NEEDED TO TURN A MODERN WIND MACHINE ?



## MATERIALS:

- 1 balsa wood dowel, 3/16" x 35.5cm
- 2 coat hangers; 6 thumbtacks
- 3 pieces construction paper, 35.5cm x 1.25cm
- 3 corks; drill; glue; 4 wooden spools ← ask anyone who sews!
- 1 piece 1/2" balsa, 5cm x 10cm
- 1 empty 1 lb. salt box; tape
- Teacher's discretion → Hobby knife; 1 sheet balsa, 1/6" thick
- Magic marker, any color

Make these 3 modern wind machines.

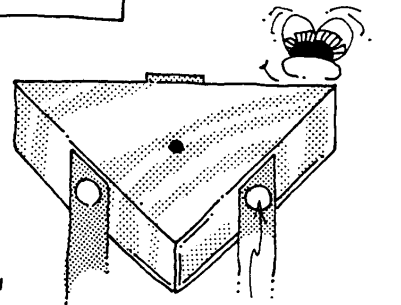
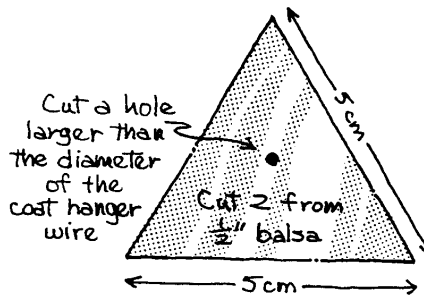

## Helix Rotor

Cut salt box in half; tape together as shown.

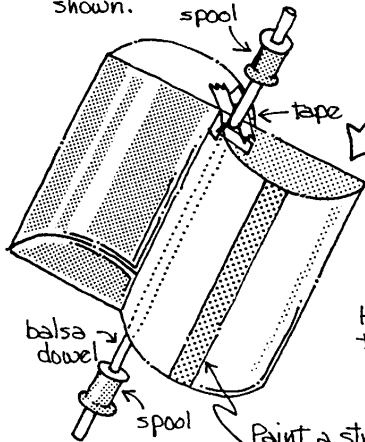

## Savonius Rotor

Punch holes and insert balsa dowel.

Hold spools - let the rotor spin in the wind!

Paint a stripe of color here with a magic marker

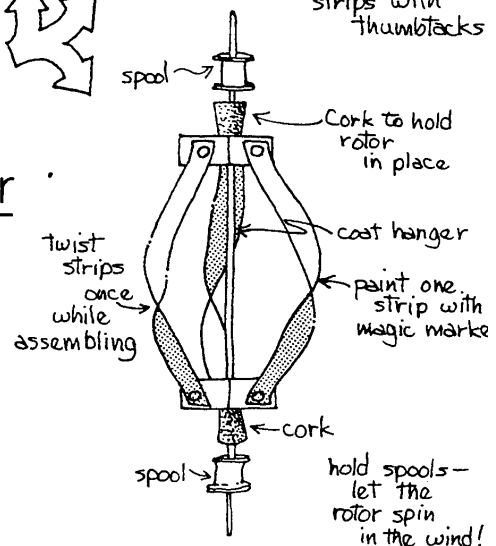

Conventional

Windmill

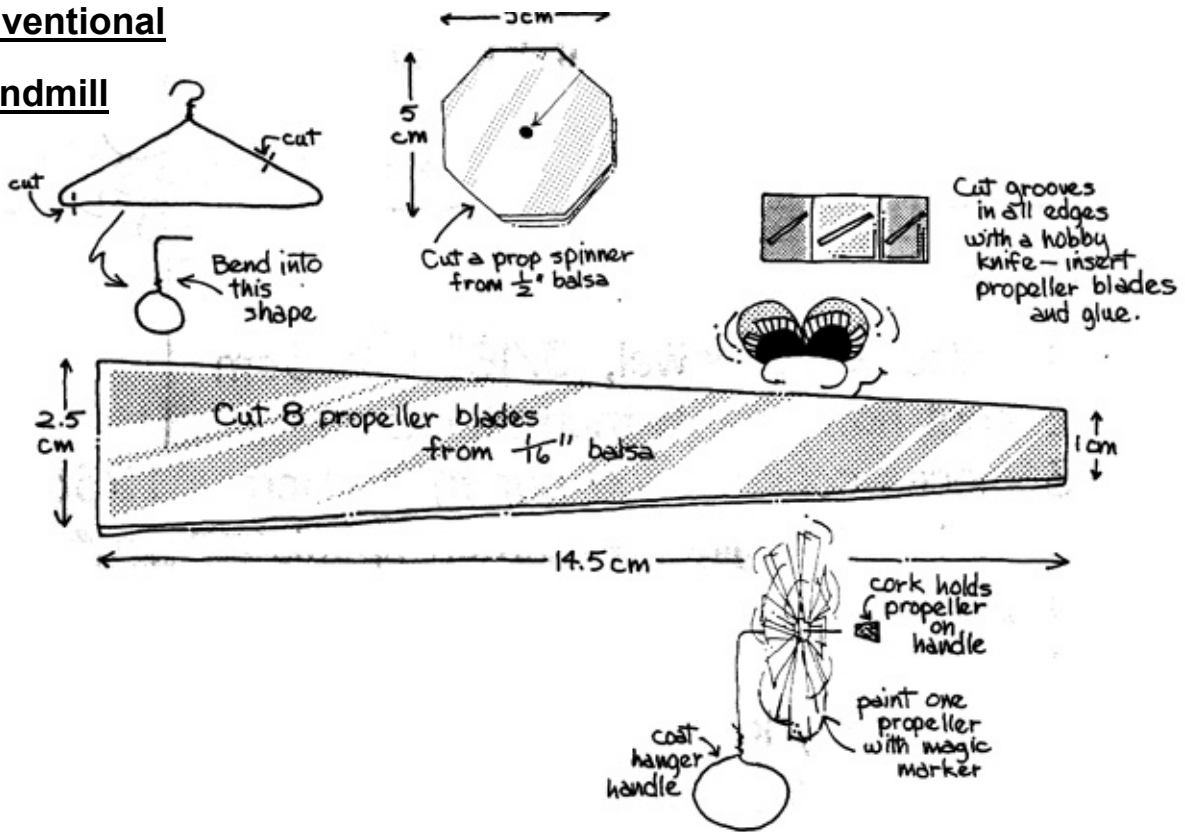

Face each of the wind machines into the wind. Use a wind measuring device to calibrate the wind speed. (See next page.)

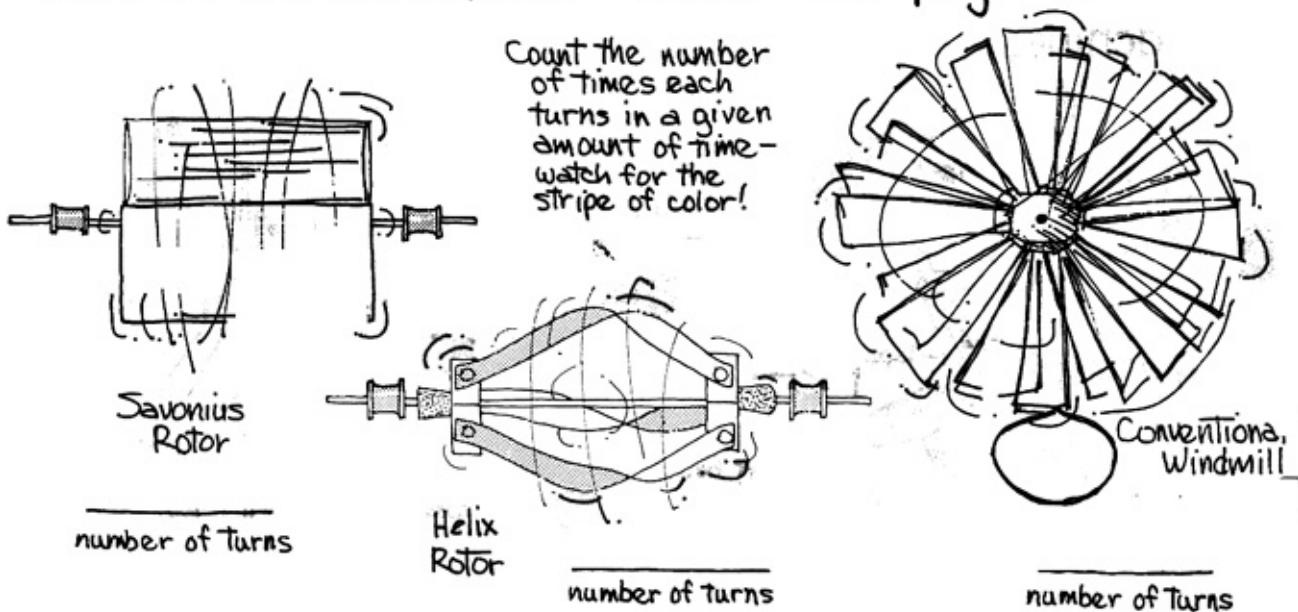

Which wind machine turns with the least wind?